

item #
 model #
 project #
 sis #
 aia #

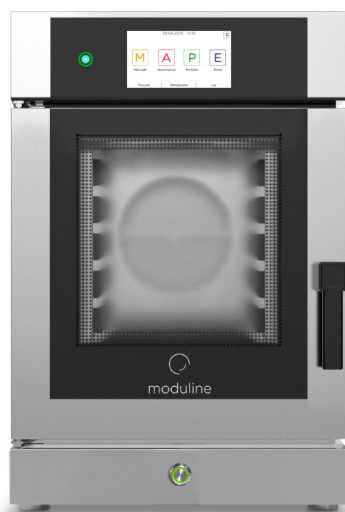

COMBI GCE060T Combi oven

CONSTRUCTION FEATURES

- Tightness chamber with radiused corners
- Total thermic insulation with rock or glass wool
- Long lasting front seals made up of food grade of high heat resistance
- Removable side racks to facilitate cleaning
- Internal drain for easy cleaning
- Ventilated heating provided by high efficiency protected heating elements

- Snap-shut door
- Adjustable feet
- Easy access to facilitate maintenance and repair
- Double low-emission glass door with internal ventilation
- Openable inside glass of the door
- Condensation drip tray under the door and connected to the oven drainage system.

FUNCTIONAL FEATURES

- Electronic control panel - 7" capacitive multitouch
- Simplified, user-friendly controls
- Periodic reversal of direction of rotation of the fan for better air distribution
- Automatic stopping of fans when the door is opened
- End-of-cycle buzzer
- Chamber with safety thermostat
- Operating temperature: from 30°C to 280°C in Convection mode, from 30°C to 280°C in Mixed Steam - Convection mode, from 30°C to 130°C in Direct Steam mode
- The cooking program can be divided into different phases
- Delta T function
- Consumption analysis function
- Automatic humidity exhaust system after cooking
- Self-diagnosis system
- Automatic telemetric registration system
- Steam condensation system
- Chamber cooling program
- USB port: software, HACCP data and recipes always at your fingertips and keeping up with the work evolution.
- EcoWash self-cleaning system

- Recipe Mix feature: once you set a program or choose a recipe, Combi suggests the food than can be cooked together to optimize time and cooking loads.
- MultiLevel function: Combi is able to manage different dishes with different cooking times or temperatures
- IdealWarm function: the intelligent temperature decrease in the cavity at the end of the cooking cycle allows perfect warm holding
- Climachef system
- FlashDry instant dehumidification function of the chamber.
- SpeedGrade fan speed adjustment
- The adaptive system for the energy calibration of the FitPower function adjusts and optimizes energy consumption based on usage.
- PadLock: key lock system with password
- ProTime system allows you to set the date and the time you want the oven to preheat or start working.
- SD Card: memory expansion with built-in SD card slot
- Multipoint core probe
- Glazed door plus lighting
- Removable GN2/3 tray racks

OPTIONS & ACCESSORIES

- | | | |
|--|--|---|
| <input type="checkbox"/> Supports | <input type="checkbox"/> Wall brackets kit | <input type="checkbox"/> Sound silencer |
| <input type="checkbox"/> Needle core probe, thin | <input type="checkbox"/> Stacking kit | <input type="checkbox"/> Air condensation hood |
| <input type="checkbox"/> Single-point core probe | <input type="checkbox"/> Water filter system | <input type="checkbox"/> Opposite side opening |
| <input type="checkbox"/> External hand shower | <input type="checkbox"/> Detergent/Rinsing agent | <input type="checkbox"/> Integral quenching system |
| <input type="checkbox"/> Built-in sliding kit | <input type="checkbox"/> Grids | <input type="checkbox"/> Door lock with key |
| | <input type="checkbox"/> Trays | <input type="checkbox"/> Power surge control set-up |

MODULINESRL

Via dell'Industria 11, Z.I. San Giacomo di Veglia 31029 Vittorio Veneto (TV) - ITALY
 tel. +39 0438 5063 - fax +39 0438 912 323 - info@moduline.it - www.moduline.it



moduline

TECHNICAL INSTALLATION DIAGRAM

Electricity supply
cable inlet



Safety vent
humidity



Chamber drain



Softened
water inlet



Adjustable vent for
excess humidity



Important - Drawing and
dimensions refer to the
standard version.
They may change with the
addition of accessories or
options.

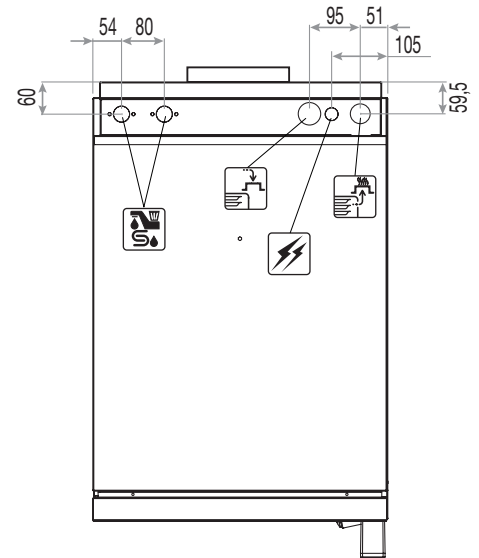
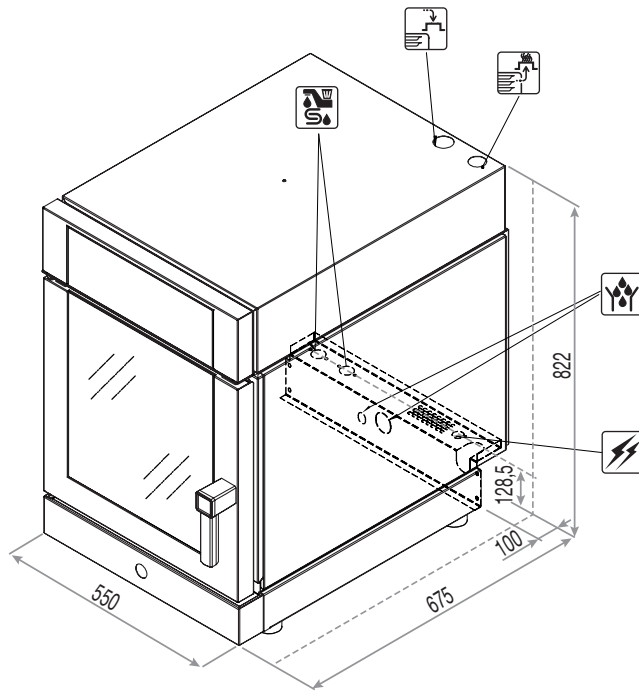

Overall dimensions
(W x D x H) - mm

550 x 675 x 822h

Product max
capacity [Kg]

10

Trays capacity

6 x GN 2/3

Total input
[kW]

5,45 (400V)

Distance
[mm]

64

Amps.
[A]

7,9 (400V)

Power supply

380-415V 3N 50/60Hz

Water pressure
[kPa]

150 ÷ 500

Working
temperature [°C]

30 ÷ 280

Net weight
[Kg]

65

Status reporting LED
/ stand-by key



7" capacitive multitouch easy-to-browse display

- Temperature control from 30°C to 280°C
- Time control
- 3 Cooking modes: convection, steam, combined convection - steam
- Automatic cooking programs divided into 6 categories
- Ability to manage up to 10 cooking phases for each program
- Favourite programs section
- Cooking with core probe
- Cooking mode with delta-t
- Climate control in the cavity with climachef system
- Recipe book customised with pictures
- Speedgrade: fans speed control
- Special features: multilevel, recipemix, idealwarm, flashdry, fitpower, protime, padlock, ecowash

MODULINESRL

Via dell'Industria 11, Z.I. San Giacomo di Veglia 31029 Vittorio Veneto (TV) - ITALY
tel. +39 0438 5063 - fax +39 0438 912 323 - info@moduline.it - www.moduline.it